

Sit back. Relax. Stay warm.

patioflare

BEACH CHAIR Item#: PF-CH369-XX

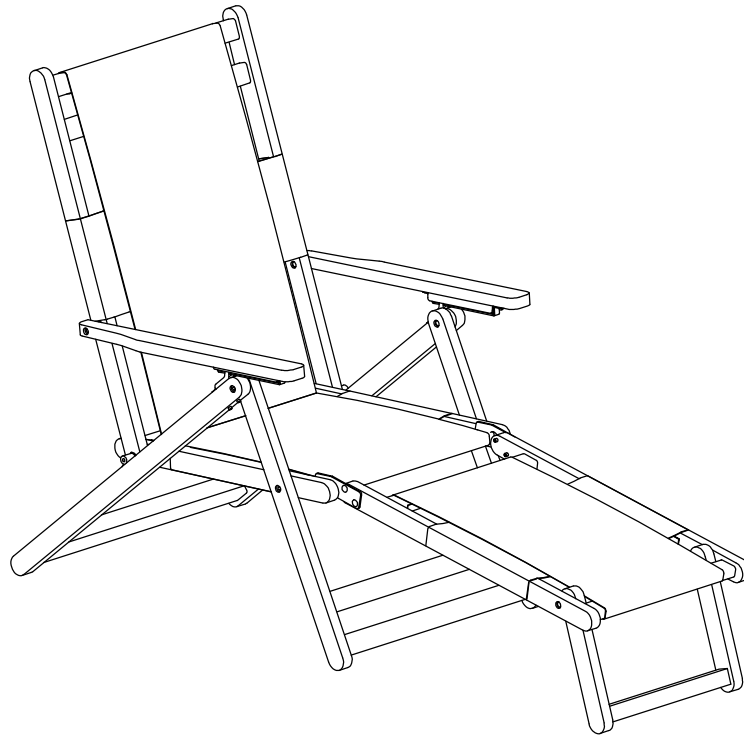

ATTACH YOUR RECEIPT HERE

Keep a copy of your proof of purchase or order confirmation which will be needed if you need to contact us about warranty coverage.

Purchase Date: _____



SAVE THESE INSTRUCTIONS FOR FUTURE REFERENCE.



Questions, problems, missing parts?

Before returning to your retailer, our exceptional customer service is available. Call us toll-free at **(800) 561-5550**, 7:30 a.m. – 4 p.m., PST, Monday – Friday or email us at **customer@jrhome.com**.



BEFORE YOU BEGIN

Before beginning assembly, make sure all parts are present. Compare parts received with the “Parts List.” If any part is missing or damaged, do NOT attempt to assemble the product. Please read and understand this entire manual before attempting to assemble, operate or install this product. If you have any questions regarding the product, please call us toll-free at **(800) 561-5550**, email us at **customerservice@jrhome.com**.

Our hours are: **7:30 a.m. – 4 p.m., EST, Monday – Friday.**



GENERAL INFORMATION

Your new beach chair is made from the finest materials available. It should provide many years of enjoyment with minimal care.

Keep your beach chair clean. For best results, clean with a soft, damp cloth. If you use furniture covers, always make sure the beach chair is clean and completely dry before covering, as mold may form in dark, wet places. Check the connectors on your beach chair regularly to make sure it is secure.

The weight limit for this beach chair is 330 LB/150 KG.



SAFETY INFORMATION

WARNING

DO NOT stand or allow children to stand on the assembled product. Make sure connectors are securely in place. Perform periodic checks to make sure the connectors are secure and adjust if needed.

CAUTION

READ all instructions before beginning assembly. Failure to do so may result in faulty assembly and potential injury. Assemble the item on a soft, non-abrasive surface such as carpet or cardboard to avoid damaging the item.

- 1** Unfold the chair and set on level surface.

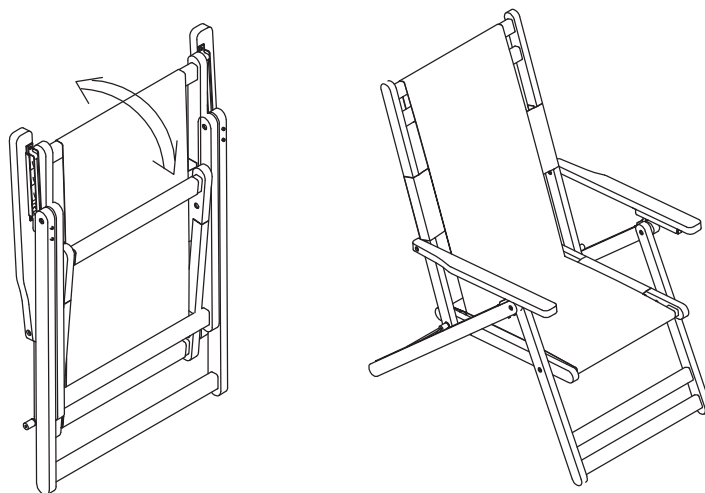

- 2** Unfold the leg of the foot rest and turn so the metal hooks face down..

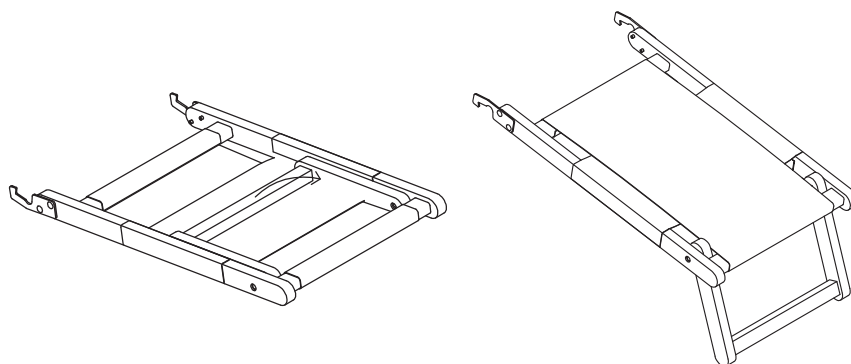

- 3** Place the hooks of the footrest over the bar at the front edge of the chair.

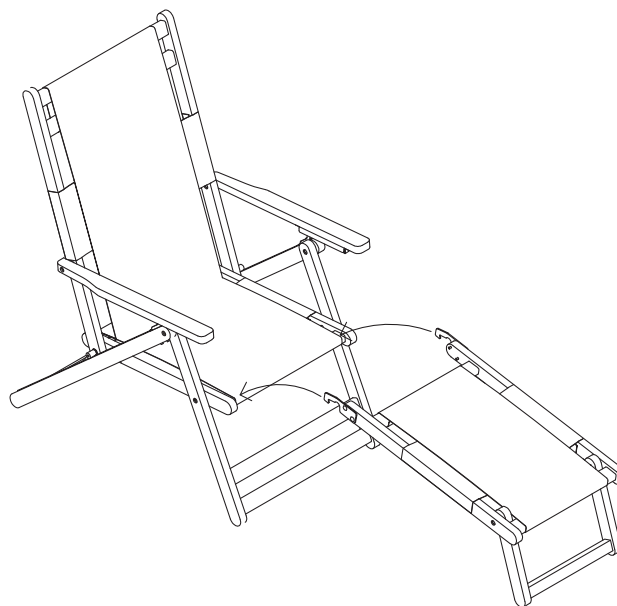

Your Beach Chair is now assembled. Enjoy your new lounge chair!

IMPORTANT

For questions, concerns or problems with our product please email our customer service department:

customercare@jrhome.com

DATED PROOF OF PURCHASE REQUIRED FOR WARRANTY SERVICE

Si vous éprouvez des difficultés ou si vous avez des questions ou des préoccupations, prière de faire parvenir un courriel à notre Service à la clientèle

customercare@jrhome.com

UNE PREUVE D'ACHAT DATÉE EST REQUISE POUR SE PRÉVALOIR DE LA GARANTIE.

WARRANTY

This product is inspected, tested and carefully packaged to minimize the chance of damage during shipment. If a part (excluding light bulbs, glass and fuses*) within one year from the date of purchase proves to be defective in material or fabrication under normal use, the part will be repaired or replaced. The Company's obligation under the warranty is to replace or repair defective parts at our discretion. Any expenses or damage resulting from the installation, removal or transportation of the product will be the responsibility of the owner and are not covered by this warranty. The owner assumes all other risks arising from the use or misuse of the product. The warranty will be void if the product damage or failure is deemed by the Company to be caused by accident, alteration, misuse, abuse, incorrect installation or removal, or connection to an incorrect power source by the owner. The Company neither assumes, nor authorizes any person or entity to assume for it any obligation or liability associated with its products. Light bulbs and fuses are not covered under this warranty. If you have any questions regarding the warranty or service, please contact us at **customercare@jrhome.com**

Customer Service:

JR Home Products

Unit 306 - 19100 Airport Way, Pitt Meadows, BC V3Y 0E2

Toll Free: 1-800-561-5550

E-mail: **customercare@jrhome.com**

AVERTISSEMENT

Ce produit a été soigneusement inspecté, testé et emballé afin de minimiser les risques de dommages durant le transport. Si l'une des pièces (à l'exception des verre, des ampoules électriques et des fusibles*) s'avère défectueuse au niveau de sa fabrication ou de ses matériaux dans l'année qui suit la date de l'achat suite à une utilisation normale, la pièce sera réparée ou remplacée. La compagnie est tenue de réparer ou remplacer les pièces défectueuses à sa discrétion, en vertu de la garantie. Tout frais ou dommage résultant de l'installation, du démantèlement ou du transport du produit demeure la responsabilité du client et n'est pas couvert par cette garantie. Le client assume tout autre risque résultant de l'utilisation, correcte ou fautive du produit. La garantie devient nulle si la compagnie détermine que le dommage ou le mauvais fonctionnement est causé par un accident, une modification, une mauvaise utilisation, un abus, une mauvaise installation ou un mauvais démantèlement ou un branchement à une source électrique inadéquate de la part du client. La compagnie n'est pas responsable et n'autorise quiconque, personne ou entité légale, à accepter de responsabilité ou obligation en son nom, en rapport avec ses produits. * Les ampoules électriques et les fusibles ne sont pas couverts par cette garantie. Pour toute question au sujet de la garantie ou du service, envoyez-nous un courriel à: **customercare@jrhome.com**.

Service à la clientèle :

JR Home Products

Unit 306 - 19100 Airport Way, Pitt Meadows BC V3Y 0E2

Toll Free: 1-800-561-5550

E-mail: **customercare@jrhome.com**

You MUST register your product to receive warranty service.

**Registration can be completed online at
www.jrhome.com or by mailing this form.**

Vous DEVEZ enregistrer votre produit pour vous prévaloir de la garantie.

**L'enregistrement sera complet une fois que vous
aurez posté ce formulaire ou s'inscrire en ligne à:**

Warranty Registration Information Form / Formulaire d'enregistrement de la garantie

Name / Nom: _____

Street / Address: _____

City / Ville: _____

Province / Province: _____

Postal Code / Code postal: _____

Daytime Phone # / No téléphone jour: _____

Evening Phone # / No téléphone soir: _____

E-Mail Address / Courriel: _____

Product/Produit: _____

Place of Purchase / Lieu de l'achat: _____

Date of Purchase / Date de l'achat: _____

Model # / No de modèle: _____

Serial # / Numéro de série: _____

You MUST register your product to receive warranty service.

For warranty service, contact J&R Home Products at the address, phone numbers listed below within 30 days of purchase. Be sure to have your sales receipt and original date of purchase. All warranty service will be coordinated by J&R Home Products service center.

Vous DEVEZ enregistrer votre produit pour vous prévaloir de la garantie.

Afin de faire valoir la garantie, communiquez avec J&R Home Products à l'adresse et aux numéros indiqués ci-dessous dans les 30 jours suivant la date d'achat. Ayez en main votre reçu et la date d'achat. Toutes les demandes liées aux garanties seront traitées par le centre de service de J&R Home Products.